

Rotary Fixture

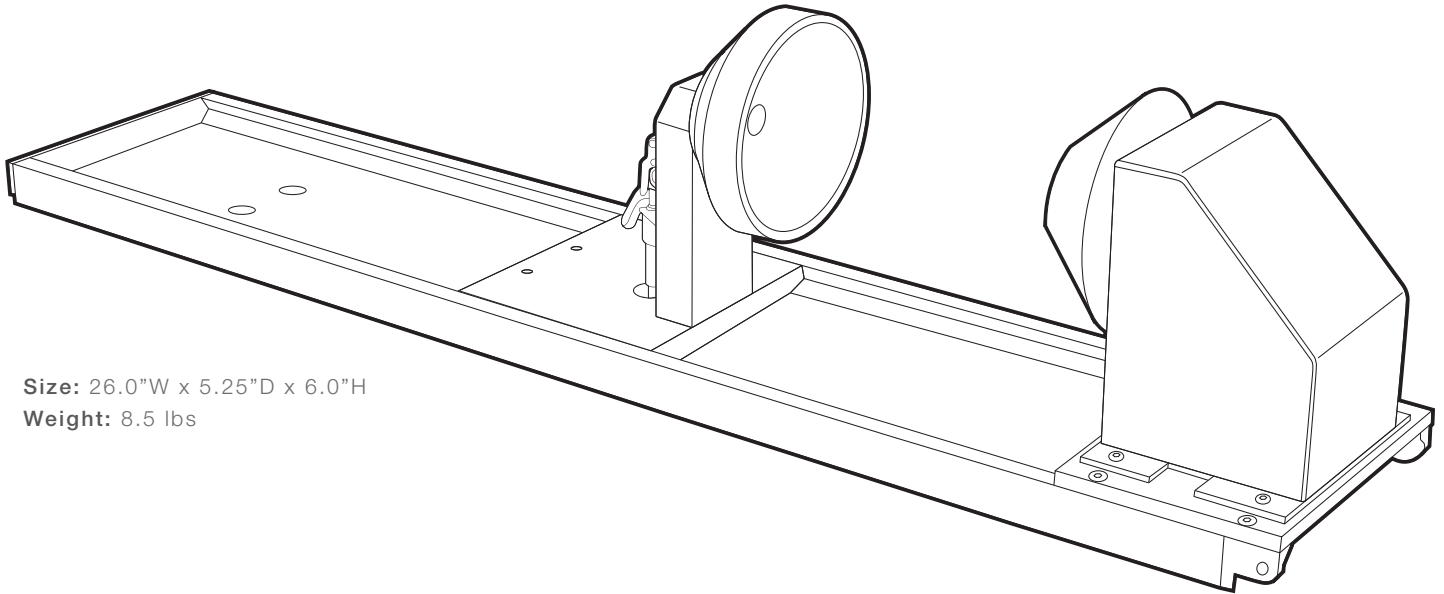

Size: 26.0"W x 5.25"D x 6.0"H

Weight: 8.5 lbs

Purpose: The high torque Rotary Fixture was developed to allow laser processing on cylindrical surfaces. It holds the part between two cones that adapt to a variety of common shapes. It also can accommodate tapered items because it allows one end of the fixture to be raised. The fixture is computer-controlled and can engrave an entire 360 degrees around an object or more if overlap is needed.

Advantage: Ability to process cylindrical objects.

Compatibility: All M, V and X laser platforms and X-650Y Yag laser systems; shipped from the factory rotary-ready.

Working Range: Items up to 8 inches in diameter and up to 16 inches long.

Installation: In the field.

Common Uses: Glassware, sporting goods, mugs and most cylindrical objects.