

Professional Series

32x18

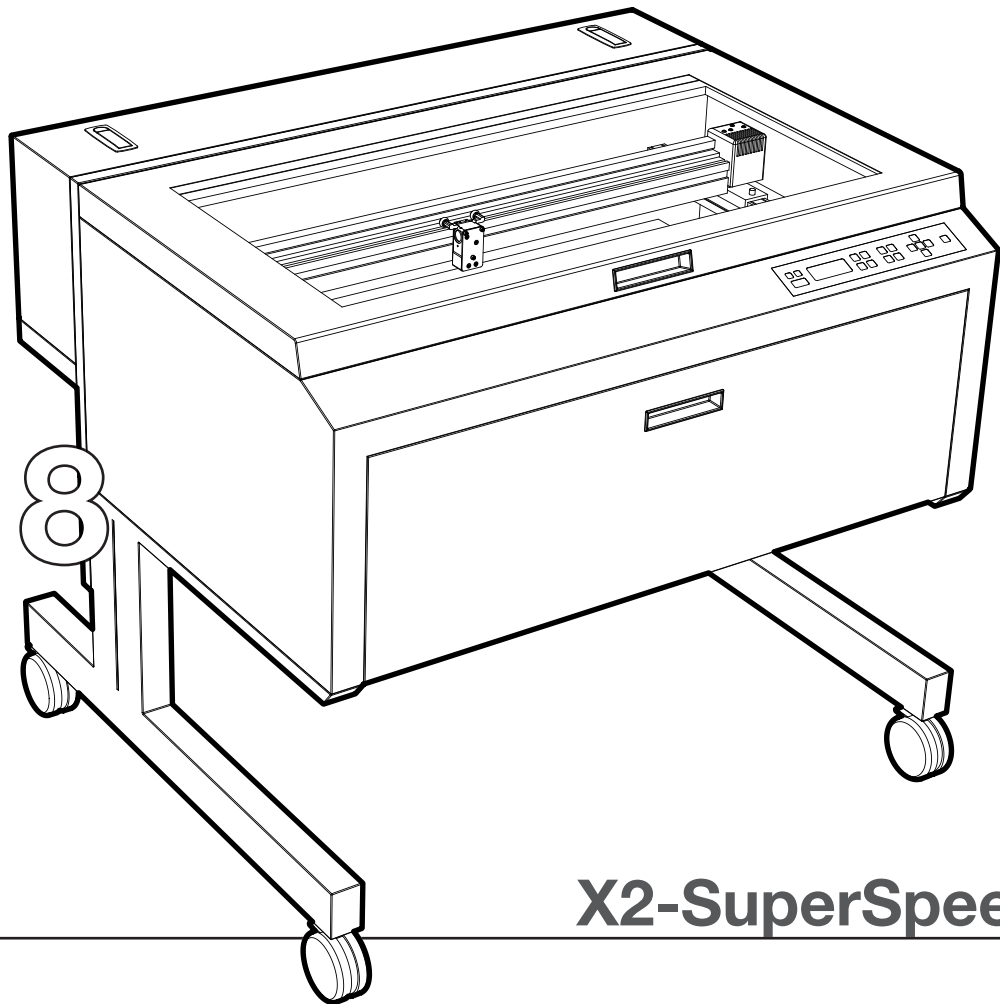

Features:

X2-SuperSpeed

Free-standing unit with integrated cart, motorized Z-axis, auto focus, X-Y beam positioning system with RACER™ motion technology, self-adjusting spring-loaded sealed bearings, stationary processing table, Computer Controlled Multi-beam Combiner™, shielded optics, interchangeable focusing optics, flash upgradeable electronics, job complete indicator, system status indicator, relocatable origin, enhanced vector cutting, 3D engraving and rubber stamp mode.

- Ultimate in speed and flexibility
- Patented, SuperSpeed™ Technology for simultaneous multi-line laser engraving or combined-beam cutting
- Large format work area
- Patented Integrated Computer-Controlled Beam Combiner™ for user-selectable laser power density
- Patented Cross-Platform Compatibility with all ULS air-cooled Quick Change Laser Cartridges™
- Patented 25-120 watt Rapid Reconfiguration Capability™
- RACER™ Motion Technology
- Complete selection of productivity accessories

www.ulsinc.com

UNIVERSAL
LASER SYSTEMS INC.

Specifications: X2-SuperSpeed™

Facility Requirements

9.3.04

Laser Compatibility	UL-25, -30, -35, -40, -45, -50, -55, or -60 watt air-cooled, RF driven, sealed CO ₂ laser(s) in the pre-aligned Quick Change Cartridge™ accommodates up to two laser cartridges of equal power.
Available Accessories	Rotary fixture, cutting table, lens kits, coaxial air assist with optics protection, dual head USB connection kit and ethernet connection kit.
Focusing Optics	Standard 2.0" (50mm) focal length lens in enclosed lens cartridge; optional lenses available.
Power Control	Digital power control continuously variable from 0 to 100%, automatic proportional pulsing and color linked power settings.
Work Area	32" x 18" (812 x 457mm)
Table Size	37" x 23" (939 x 584mm)
Maximum Part Size	37" wide x 23" deep x 9" thick (939 x 584 x 228mm)
Computer Interface	Parallel port standard. USB and ethernet optional. Compatible with Windows® 2000/XP.
Memory Buffer	Intelligent buffer with automatic data compression stores up to 99 files with all settings; files are addressable and repeatable in any order and may be deleted after completion to free memory; buffer can be switched to single file mode.
Display Panel	LCD display shows current file name, laser power, engraving speed, run time, files loaded into memory buffer, setup and diagnostic menus.
Operating Modes	Optimized landscape SuperSpeed mode or combined beam landscape mode with raster or vector engraving and vector cutting.
Dimensions	39" high x 44" wide x 37.5" deep (990 x 1117 x 952mm)
Weight	Approximately 345 lbs (156kg)
Safety	Meets CDRH and EN60825-1 requirements for Class 1 laser safety enclosure for CO ₂ laser and Class 3R for red pointer.

Electrical	Single phase 220 VAC, 15 amp, 50/60 Hz
Exhaust	Outside exhaust required. Two 4" (102mm) connections requiring 500 CFM total (250 at each connection) air flow at a static pressure of 6 inches of water (425m ³ /hr at 1.5kPa each connection).
Cooling	Air-cooled, ambient operating range of 50°-95°F (10°-35°C).

The SuperSpeed feature splits the combined laser beam into two side-by-side beams to engrave two lines of an image simultaneously and automatically recombines beams for maximum depth vector cutting or engraving, dramatically increasing productivity.



©2004 Universal Laser Systems, Inc. Protected under one or more of U.S. patents 5,661,746; 5,754,575; 5,867,517; 5,881,087; 5,894,493; 5,901,167; 5,982,803; 6,181,719; 6,313,433; 6,342,687. Other U.S. and International patents pending. Specifications subject to change without notice. Windows is a registered trademark of Microsoft, Inc. Mac OS9 is a registered trademark of Apple Computers, Inc.