

AIR ASSIST

V Class / X Class
V-400 / X-600 / X2-600
Models

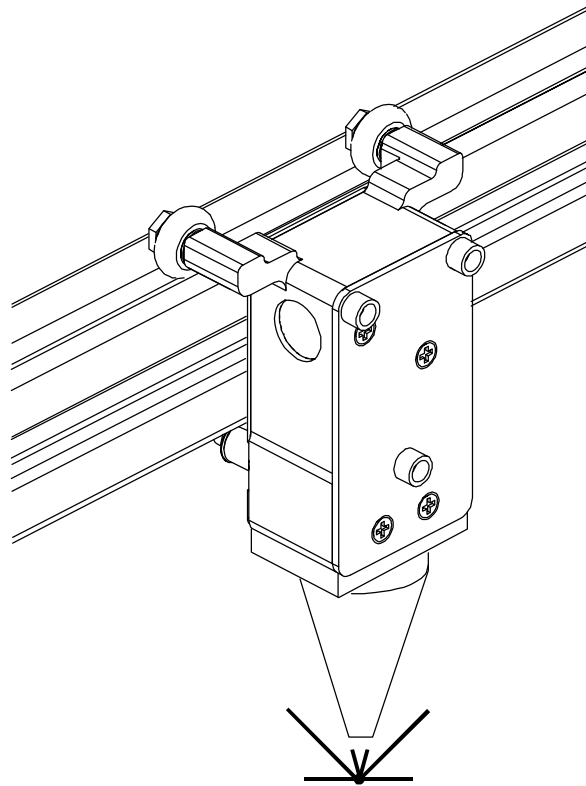

Operation Instructions

11/15/00

NOTICE

Before attempting to use this option, please read the Operations manual included with the laser system. It is vital that you have a complete understanding of how the laser system works before attempting to use this option. Incorrect or inappropriate usage of the Air Assist option may be a safety hazard and may cause severe damage to the system.

Purpose

The Air Assist option has been developed primarily to reduce flaming during the cutting process or can be used to help push debris away from the material during the engraving or cutting process. In addition, this option has been engineered to also assist in reducing optic contamination that may result from using this option.



This option IS NOT intended to decrease maintenance of the laser equipment. Using the Air Assist option has been known to cause an increase in the frequency of cleaning maintenance due to debris being blown around, inside the engraving chamber, during the process.

Requirements

The Air Assist option requires compressed air supplied from the Air Assist Compressor Unit (optional) or from a user supplied compressed air source. If you choose to provide your own source, it must be capable of supplying 50 PSI (pounds per square inch) at a constant rate of 2.5 CFM (cubic feet per minute). **The air supply MUST be oil-free, moisture-free, and particulate filtered. A contaminated air supply may cause severe damage to the laser system.**

The Air Assist option also allows the use of an inert gas supply, such as Nitrogen (user supplied). Inert gases can be used to assist laser cutting or engraving by reducing the heat effect or the melting of the work piece during laser processing. To use an inert gas, an external gas tank with a pressure regulator is required. Using an inert gas does not replace the need for compressed air. Inert gas users must provide the regulated gas **AND** a clean compressed air supply. The gas will **ONLY** flow through the Cone to the work piece and the compressed air will provide the optics protection.

Most users only provide a compressed air supply that serves both purposes.

Making the Connections

In the left rear part of the system you will find the Air Assist Control Box. Attached to the box, there should be two special Quick Release Couplings secured with plastic tie wraps (1). Using a pair of scissors or wire cutters, cut off the plastic tie wraps and discard.

The AIR IN (2) fitting is where you attach the compressed air supply. The GAS IN (3) fitting is where you would attach an inert gas supply (optional). If you purchased the optional Compressor Module you would connect the control wire to the AUX OUT (4) connector (refer to the Compressor Module instructions for more details). The HIGH (5) and LOW (6) pressure adjustment screws are used to adjust airflow to the work piece (through the Cone) during operation. You can monitor the pressure by observing the Pressure Gauge (7) during operation.

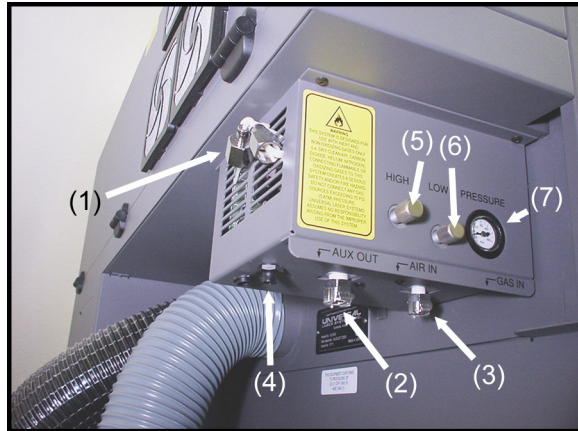

- 1) Quick Release Couplings
- 2) AIR IN fitting
- 3) GAS IN fitting
- 4) AUX OUT connector
- 5) HIGH pressure adjustment
- 6) LOW pressure adjustment
- 7) Pressure Gauge

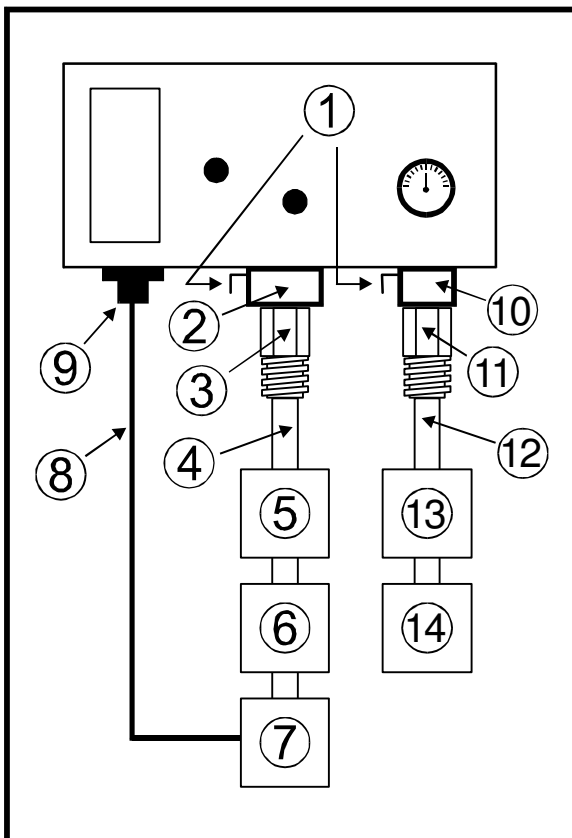

Locate the Locking Lever (1) attached to both fittings. Push in the lever until it clicks. Attach the larger Quick Release Coupling (3) (1/4 NPT threads) to your compressed air supply line (4). Use thread sealant or Teflon tape to prevent leaks. Push the Quick Release Coupling (3) into the fitting (2) until it clicks into place. Attach the other end of the supply line (4) to a Particulate Filter (5), Desiccant/Dryer (6), and then to an oil-free compressed air source (7). If you have purchased the optional Compressor Module, connect the Control Wire (8) from the Compressor Module (7) to the AUX IN connector (9). If using an inert gas, attach the smaller Quick Release Coupling (11) (1/4 NPT threads) to the supply line (12) using thread sealant or Teflon tape. Push the Quick Release Coupling (11) into the fitting (10) until it clicks into place. Attach the other end of the supply line (12) to an external Pressure Regulator (13) and then on to the Gas Tank (14).

Cone Installation and Removal

The Cone must be attached to direct the air or gas supply to the laser beam's focus point. Locate the Set Screw (1) on the side of the Cone Base (2). **DO NOT** remove or loosen the Cone Base Mounting Screws (3) & (4) to mount or dismount the Cone. These screws keep the Cone Base aligned with the laser beam. The Cone installs and removes using a different method.

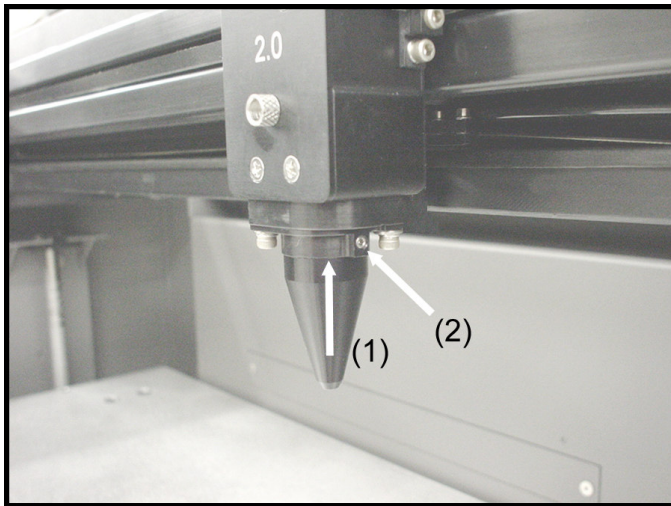
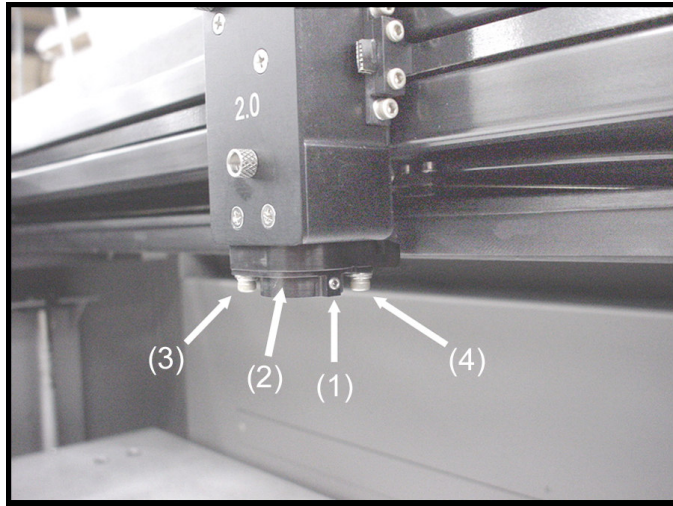

To install the Cone, insert the Cone (1) into the Cone Base completely until it bottoms out. Using a .050 inch Allen wrench, tighten the setscrew on the side of the Cone Base (2) until it is snug. Re-check to make sure that the Cone is all the way into the base and is not tilted. To remove the Cone, simply loosen the setscrew and pull the Cone straight down.



DO NOT install the Cone unless you plan on using Air Assist. Leaving the Cone attached to the Cone Base and running the laser system without either air or gas flowing through the Cone will destroy the Focus Lens within a few minutes. If you are not using Air or Gas Assist, **REMOVE THE CONE**. Damage of this nature is due to neglect and **WILL NOT** be covered under warranty.

How it Works

The Control Box (1) (represented by the dotted lines) directs the compressed air source to the optics protection path and also to the Cone. The optics protection path is a direct path from the entry point of the compressed air source (2) to the Beam Window (3), the #2 Mirror (4), and #3 Mirror (5). The air supply for the Cone comes from either the HIGH (6) or LOW (7) solenoid valves, through the HIGH (8) or LOW (9) pressure adjustment valves, through the Pressure Gauge (10) and finally to the Cone. The Cone path protects the Focus Lens (11) and provides a downward flow directly into the beam path at the focus point. You choose which solenoid valve (6 or 7) to open through the laser systems printer driver. The Gauge (10) will ONLY show a reading when either the HIGH (6) or LOW (7) solenoid valve is opened and air is flowing to the Cone. If you choose to use an inert gas to supply the Cone, the supply must go through the GAS coupling (12), through the Gas Solenoid Valve (13) and finally to the Cone. The GAS path bypasses the pressure adjustment valves and the Gauge so it must be regulated externally. Only one solenoid valve (6,7, or 13) can operate at one time.

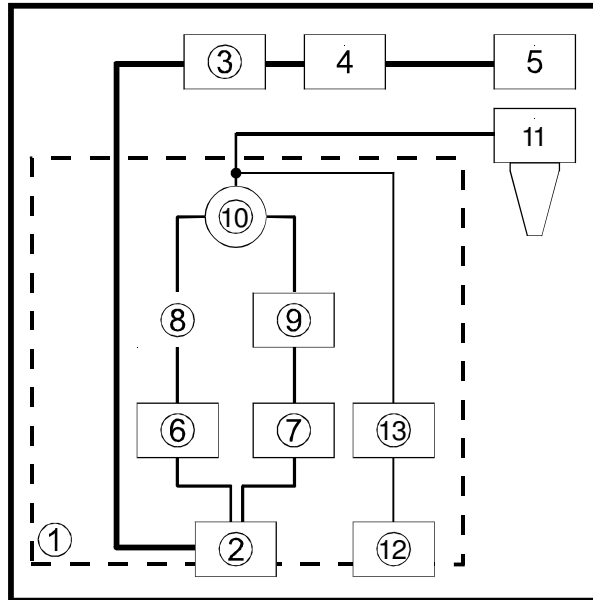

As the diagram indicates, the optics protection path is neither regulated nor solenoid valve controlled. If you are using your own compressor, the optics protection air will always be flowing regardless of whether the laser system is running or not. You must install either a manual shut off valve (not supplied) or an external electronic solenoid valve system (not supplied). If you purchased the Air Compressor option the optics protection air will turn ON and OFF as the compressor turns ON and OFF respectively.

When you press the “Start” button on the laser system, the Air Assist Control Box will send out a +5 VDC signal through the AUX OUT control wire, which can be used to turn ON the Air Compressor (optional) and will keep the Air Compressor ON until the file completes. This type of control saves electricity, reduces the running time of the compressor, and reduces ambient noise when the laser system is not running.

The Control Box also has built in pressure sensors that will detect insufficient supply pressure and will shut down the laser system. An error message, “Warning Air Pressure?” will appear on the display, indicating that there is a problem with your supply of either air or gas.

Control Panel Selections

Before you run your material, we suggest that you adjust your air and/or gas flow. To do this, you must first power ON your laser system, activate your compressed air supply, and your gas supply (if applicable). After the laser system finishes "INITIALIZING" and goes to "READY", press the "ESCAPE" button once. Bring the cursor down to "PREFERENCES" and press "SELECT". While the cursor is on the "CONFIGURATION" line, press "SELECT" again. Position the cursor on the "AIR ASSIST" line. Now, by pressing "SELECT" you can toggle that option through four choices, "AUTO", "AIRL", "AIRH", and "GAS".

AUTO

This is the default selection. It allows the Control Box to be automatically controlled by printer driver selections. It also serves as an "OFF" selection if you choose "OFF" in the printer driver.

AIRL

Manually activates the "LOW" valve solenoid when the "START" button, on the laser systems control panel, is pressed.

AIRH

Manually activates the "HIGH" valve solenoid when the "START" button, on the laser systems control panel, is pressed.

GAS

Manually activates the "GAS" valve solenoid when the "START" button, on the laser systems control panel, is pressed.

Adjusting Air or Gas Flow

We now need to set the flow rate through the cone. We can do this by manually activating a solenoid valve and adjusting the needle valve to achieve desired flow through the cone. With your laser system powered ON and NO files downloaded to the laser, select "AIRL" in the control panel. Press the "ESCAPE" button several times to get back to the "FILE DISPLAY" menu. Now press the "START" button. You will hear and audible "click" and the air will start flowing through the cone. With the top door of the laser system open, pass a piece of paper underneath the cone and use it to note the amount of air flowing through the cone and against the paper. Adjust the "LOW" Pressure Adjustment Valve until either the desired airflow or PSI reading on the Gauge is achieved. Clockwise adjustments reduce flow while counterclockwise adjustments increase flow. If you close the Pressure Adjustment Valve too much, there might not be enough flow to keep the pressure sensor inside of the Control Box activated. This can trigger a "Warning Air Flow?" message to appear on the display of the laser system. If this happens, press "Escape", open the needle valve, and try it again. **DO NOT** adjust the Pressure Adjustment Valve while there is NO air flowing as air flow through the cone is required for the Gauge to display actual flow. Once desired flow is achieved, press the "PAUSE" button to deactivate the solenoid valve. Repeat the above procedure to set the "AIRH" (HIGH) solenoid valve pathway to the Cone.

To set the GAS pressure (if applicable), repeat the above procedure again with the exception that your gas flow has to be regulated and adjusted by an external regulator mounted on the gas tank or in-line between the tank and the laser system.

Once you have set your flow rates for each pathway that you will be using, reset the laser systems control panel so that the “AIR ASSIST” option displays “AUTO”. This will allow your selections in the printer driver to activate the correct solenoid valve choices.

Programming the PC Printer Driver

The Air Assist option provides printer driver controlled activation and deactivation of solenoid valves that direct the flow through one of three paths with its final destination being the Cone. It also has been designed to work in conjunction with the optional Air Compressor to turn it ON and OFF when the job starts and finishes, respectively. The Needle Valves control flow through the Cone when the solenoid valves are activated. The Gauge provides a visual indication of how much flow is going through the Cone. You can choose between “LOW”, “HIGH”, or “GAS” valve activation setting for each one of the eight colors in the printer driver.

Power up your PC and open up or create a graphic to print to the laser system. When ready to print, go to the laser system printer driver and set all of your parameters. If you do not know how to use the Printer Driver, please refer to the Users Manual. Next to the color choice is the button for the “Gas Assist” option. Click once on it and it turns to “LOW”. A second time and it turns to “HIGH”. A third time and it turns to “GAS” and a fourth time turns it “OFF”. Choose which pathway you desire.

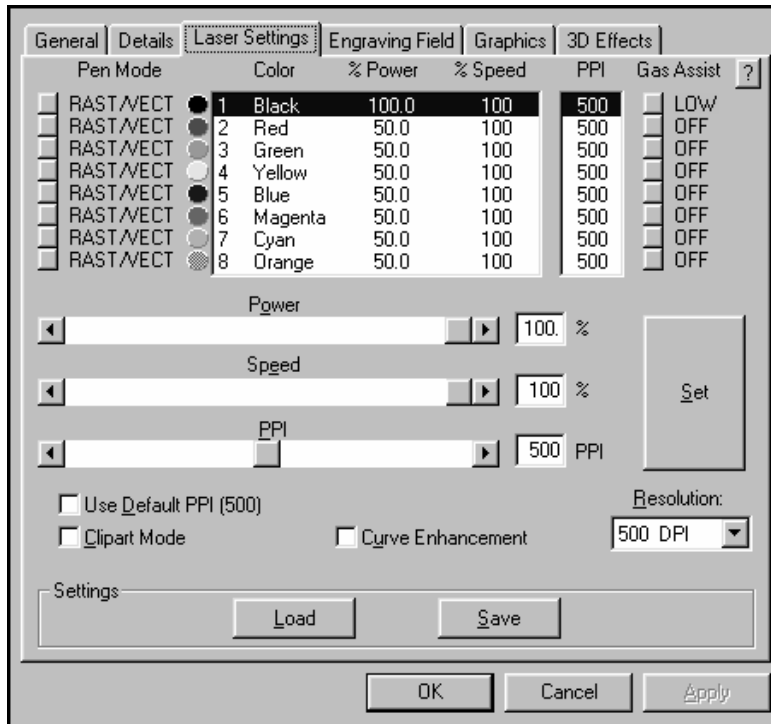

Choose the rest of your parameters and download the file to the laser system. Make sure the Cone is installed. Insert your material into the laser system and set the focus.

Make sure that you air and gas supplies (if using) are ON. Turn on your exhaust blower and press the “START” button.



DO NOT supply external air or gas pressures higher than 50 PSI. Pressures over 50 PSI can rupture the internal hoses of the Control Box and can possibly damage the valves. Damage from this type of abuse will **NOT** be covered under warranty.

Air Flow Setting Guidelines

Use as much or as little air flow necessary to produce the desired results. There are no particular settings that we can offer to you. As a rule of thumb, start with low flow and adjust upward until flaming is suppressed. Setting the flow too high can result in excessive particulate matter being blown around causing faster system contamination, which would require an increase in maintenance. It can also push the hot engraving or cutting smoke back onto the material or into the cut line and cause contamination of the surface or side edges of the material. On some scrap material play around with different flow settings to obtain the best results, then write down your settings for various materials. Remember, the intent of the Air Assist option is to suppress flaming and/or melting of the material during laser processing.

Maintenance

- Keep you air supply and/or gas supply moisture free. Check your desiccant (water dryer) frequently. Replace desiccant when saturated or use the manufacturer’s recommendation to remove water moisture from the desiccant crystals. Water moisture may contaminate the air assist system and can cause malfunctions as well as damages to the unit.
- Clean your laser system more frequently when using Air Assist. You will need to check, and possibly clean, your optics frequently. Do not let the optics protection part of the Air Assist system lead you to a false sense of security. Since more debris gets kicked up by the downward air or gas flow through the Cone, the laser systems rails, bearings, and other motion system components will get dirtier faster than by not using the Air Assist option.
- Periodically check the cone alignment with the laser beam especially if you have replaced or adjusted the laser systems optics. You will know if your Cone is not aligned if you suffer a substantial loss in laser power when laser cutting or engraving with the Cone installed as opposed to the Cone removed. A misaligned Cone will cause the beam to make contact with the inside of the Cone, possibly splitting the beam and/or reducing the power at the focus point.

Cone Alignment Check and Adjust

1. Power the laser system ON.
2. Open the top door.
3. Position the focus carriage in the middle of the field.
4. Turn ON the Red Diode laser pointer.
5. Place a piece of paper (1) underneath the Cone and observe the position of the red beam (2) in relation to the center of the bottom of the Cone (3) and be sure to check it from the front and side.
6. If the red beam is not centered, remove and reinstall the Cone to see if it was due to an improperly installed Cone.
7. If the red beam is still not centered, check all your optics for looseness or mechanical misalignment.
8. If still not centered, loosen the two Base Mounting Screws (4) slightly (1/4 turn) and slide the Base (5) around until the red diode laser comes out of the centered of the Cone. Remember to check this from the front and side of the Focus Carriage.
9. Tighten the Base Mounting Screws (4) gently and re-check the Cone's alignment.

