

VersaLASER VLS2.30 and VLS3.50

Keeping the laser system clean will ensure the highest quality engraving. A clean laser system is the best performing laser system. The frequency of cleaning will depend on the type of material being engraved, your exhaust system, the operating environment and the amount of laser system usage over a given period of time.

Dirt or debris build-up on the motion system components will cause uneven or rough engraving, or loss of engraving position, as well as component failure. Smoke or dirt build-up can cause damage to the optics, result in loss of laser power or result in premature failure of these components. Always turn the laser engraving system OFF and unplug it before performing any cleaning procedures.

Motion System Components Diagram

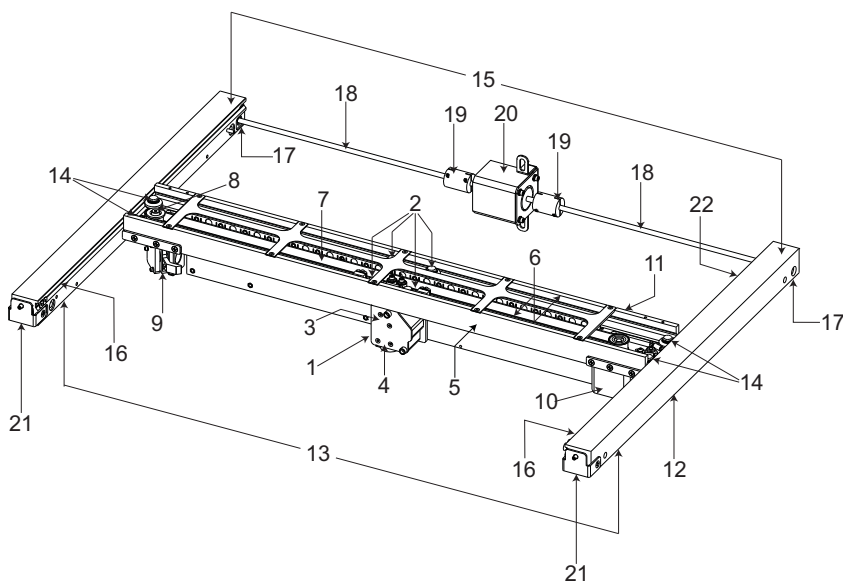

1. Focus carriage
2. X-Axis bearing (4)
3. #3 mirror (inside cover plate)
4. Focus lens (inside cover plate)
5. X-Axis rail (arm)
6. X-Axis bearing track (2)
7. X-Axis belt
8. X-Axis idler pulley
9. #2 mirror and holder
10. X-Axis motor and drive gear
11. X-home sensor board
12. Y-home sensor board
13. Y-Axis belt (2)
14. Y-Axis bearing (4) (2 on right side Y-Axis rail, 2 on left side Y-Axis rail)
15. Y-Axis rail (2)(one right side and one left side)
16. Y-Axis rail bearing track (2) (one on right side, one on left side)
17. Y-Axis drive gear (2) (one on right side, one on left side)
18. Y-Axis shaft (2) (one on right side, one on left side)
19. Y-Axis shaft flex coupler (one on right side, one on left side)
20. Y-Axis motor
21. Y-Axis idler pulley (2) (one on right side, one on left side)
22. Y-Axis home sensor magnet

Note: #2 Mirror Cover and X-Axis Rail Cover have been removed for visibility.

Cleaning and Maintenance Supplies

- Mild soap solution mixture of 1 tablespoon (14.78 ml) liquid soap and 1 quart (liter) of water in a spray bottle
- Window cleaner
- Paper towels
- Cotton cloth
- Denatured alcohol (NOT to be used on any painted surface, plastic or the Top Window)
- Acetone (can be used on the engraving table, but nowhere else)
- Cotton swabs (supplied)
- Lens cleaner (supplied)
- Vacuum cleaner
- Set of Allen wrenches sized from 0.050 to 3/16 inch

CAUTION: When using acetone or denatured alcohol, please follow the instructions on the printed label of these materials for safe handling procedures.

System Cleaning and Maintenance

Motion System

- Using a vacuum cleaner, vacuum all loose dirt and debris from the inside of the device.
- Outside the device, dampen a paper towel, cotton cloth or terry cloth with the soap solution, alcohol or acetone and wipe down the Z-axis Table. Be careful not to spill any chemical on any painted surface.
- Locate the four X-Axis Bearings (1). Dampen a cotton swab with a soap solution. Place the dampened swab against the bearing (2), grasp the focus carriage (3), slide the focus carriage left and right, allowing the bearing to roll in the v-groove (4). Pay attention to the part of the bearing that contacts the v-groove both on the top and the bottom side of the bearing. Also, use the dampened swab to clean the v-groove (4). Make sure you clean all four bearings.

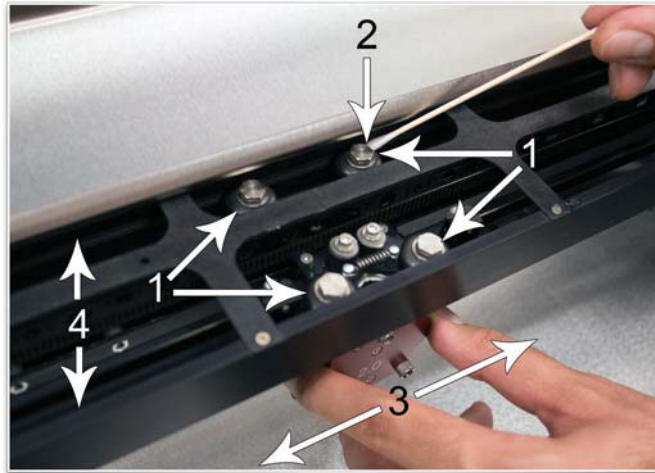

- Locate the left and right side Y-Axis Rails and their respective v-grooves as the arrows in the photos indicate. This is where the Y-Axis Bearings (not visible) make contact with the rail. Dampen a cotton swab or cotton cloth with soap solution and clean the v-groove. Gently slide the X-Axis Arm toward the front or rear of the device so that you have access to the entire length of the v-groove.



Optics

A visual inspection of the optics should be performed at least once a day. If the optic appears cloudy or has material deposits formed on the surface, it should be cleaned. If, after inspection, the optic appears visually uncontaminated, do not clean the optic. Excessive cleaning can damage the optic. The guidelines listed below describe how to handle optics:

Optics Handling Guidelines

- Wash your hands thoroughly before handling any optic.
- **Never** touch the surface of the optic with your fingers.
- **Never** clean any optic immediately after using the VersaLASER. Wait for the optic to cool, at least 3-5 minutes, otherwise it may crack from thermal shock.
- **Do not** use compressed air to clean the optic.
- **Do not** clean an optic that is visually clean. Excessive cleaning may damage the optical coating.
- Use only cotton swabs and approved lens cleaner or reagent grade acetone to clean the optics.

Optics Cleaning Procedure

- Dampen a clean cotton swab with lens cleaner.
- Gently wipe the optical surface with the damp swab. **Do not rub hard.**
- Control the wiping speed so that you do not leave streaks. If streaks remain, dampen an unused cotton swab with reagent grade acetone and gently wipe the optical surface to remove the streaks.

#2 Mirror

1. Slowly slide the X-Axis Arm forward.
2. Grasp the bottom lip of the cover and rotate the cover up. The cover is held down by magnets so it may “stick” slightly when you first begin to rotate it.
3. Locate the #2 Mirror Holder (red). Grasp its protruding handle with your thumb and forefinger and slide it out. It is held in place by magnets so you may feel a slight resistance when you begin to slide it out. The picture reveals the backside of the mirror.



4. Turn the #2 Mirror Holder over and inspect the optic for visual contamination. Clean as necessary.
5. Re-insert the #2 Mirror Holder by sliding it into the mounting slot until it stops.

CAUTION: Installing the mirror backwards will cause the handle to protrude in such a way that the X-Axis Arm cover will not close properly and will destroy the mirror once the laser beam penetrates the backside of the mirror. Be sure to re-install the mirror correctly.

#3 Mirror and Focus Lens

1. Loosen the two thumbscrews (1) completely. They are held captive by retaining clips so they will not come out all the way.
2. Grasp the red Front Cover Plate (2). Gently slide it forward and out of the Focus Carriage (3).

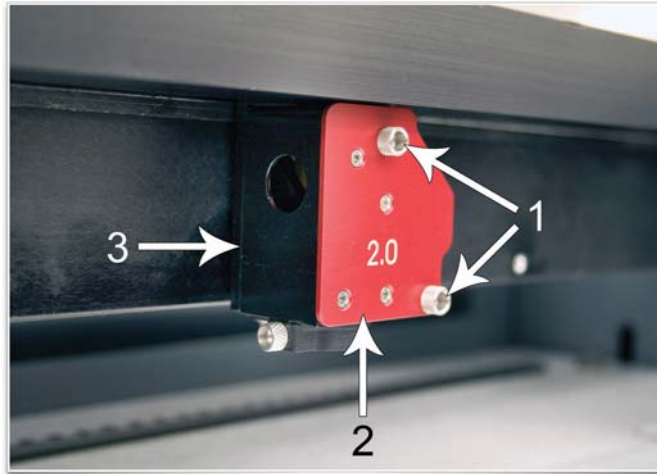

3. Inspect the #3 Mirror (1) and Focus Lens (2) and clean as necessary. Be sure to inspect the top and bottom side of the Focus Lens.

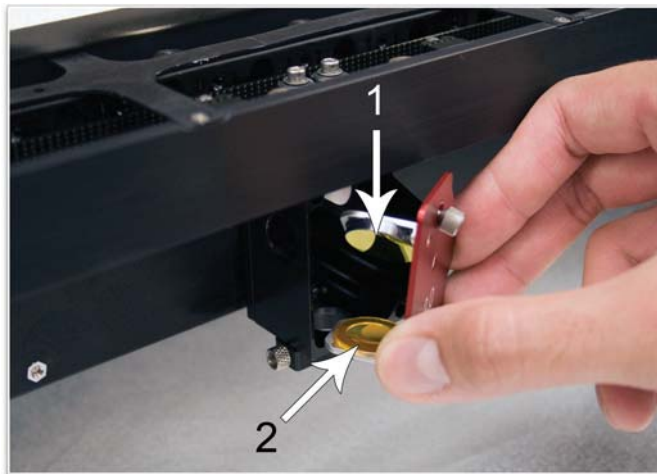

Beam Window

- The Beam Window (1) is where the laser beam enters into the processing area. It is located in the upper left hand corner, towards the rear of the laser system.
- It is only necessary to clean the front side of the Beam Window. The backside is in a sealed environment and should not get contaminated.
- **Do not** remove the Beam Window for inspection or cleaning. Inspect the optic in place and clean if necessary.

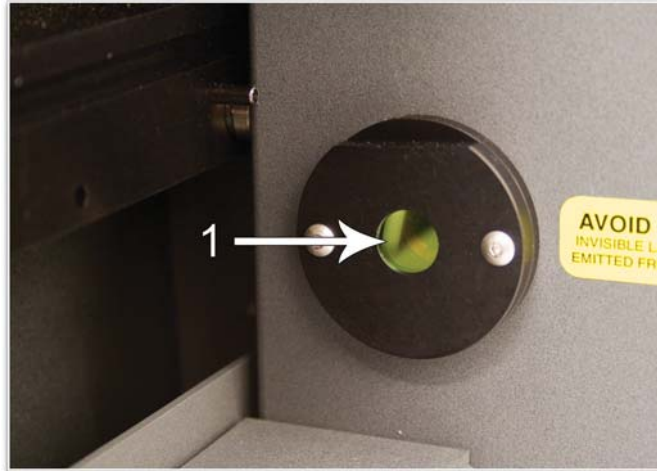

Main Enclosure

- Clean the glass Top/Front door with a non-abrasive cotton cloth, paper towel or facial tissue and window cleaner. The top window is made out of glass; therefore, **do not** use abrasive cleaning clothes because they will scratch the glass. Also, **do not** use abrasive chemicals that will damage the glass. Only use cleaners compatible with glass.
- Use a soft cloth dampened with the soap solution to clean the enclosure. **Do not** use alcohol, acetone or any other harsh chemical as these will damage the paint.

Adjustments and Lubrication

- Periodic adjustments are not required.
- The bearings in the motion system will self-adjust to take up any clearances as they begin to wear. All bearings in the system are sealed and do not require lubrication. **Do not** lubricate the bearings.
- The belts are fiber-reinforced and will not stretch under normal use.
- Optical alignment is not necessary under normal use.

Interlock Safety Check

The user door is safety interlocked. To verify that it is functioning normally, perform the following test:

1. Power on the VersaLASER.
2. Without any job running, open and close the user door.
3. Observe the Red Dot Pointer turning on and off respectively.
4. If there is no change while opening and closing the door, power off the VersaLASER and contact our Customer Service Team immediately at 480-609-0297 (USA), +43 1 402 22 50 (Austria), +81 (45) 224-2270 (Japan) or e-mail us at support@ulsinc.com.
5. **Do not** use the device until the problem has been corrected.

Fuse Replacement

If the power input fuses are blown, this indicates that there can a problem with a component inside the VersaLASER and that component must be repaired or replaced, otherwise the replacement fuses will also blow. This can also be caused by a power surge or spike. Please contact our Customer Service Team at 480-609-0297 (USA), +43 1 402 22 50 (Austria), +81 (45) 224-2270 (Japan) or support@ulsinc.com if the fuses blow.

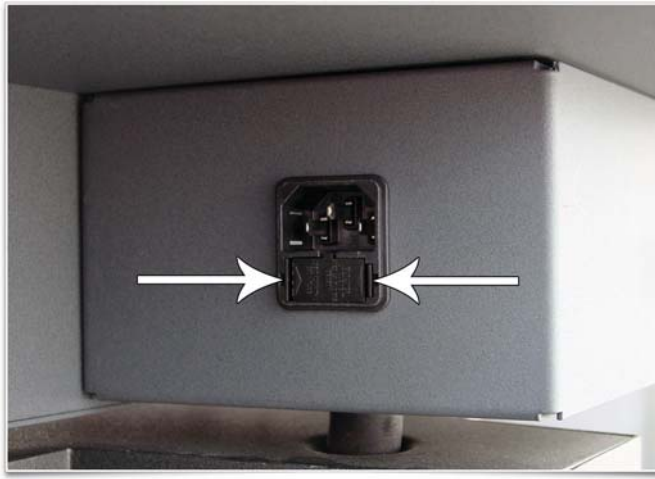

The fuses are located on the bottom of the power input plug receptacle. To remove and check or replace the fuses, use a small screwdriver or your fingernails to push the two retaining tabs (arrows) toward each other and pull out the fuse holder.

Pull out the two fuses from the holder and check them with an ohmmeter or for visual damage. When reinstalling the fuses, be sure to push the holder in all the way until it “clicks” into position.

Cooling Fan Filters

1. The side (1) and rear (2) cooling fan filters are located inside the Rear Cover.
2. To access them, remove the two mounting screws (3) underneath the rear of the system.
3. Lift the cover straight up and off.
4. Locate the filters on the inside of the cover (not shown).
5. Remove the plastic retainer and the filter media.
6. Rinse the filter media with soap and water.
7. Allow them to air dry or dry them before re-installing.

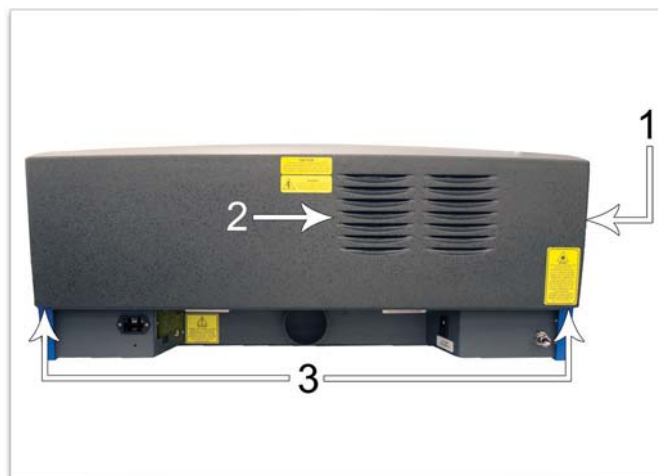

Maintenance Schedule

Since the maintenance requirements of the laser system are dependent on the type of material being run, the quantity of material being removed, the hours of operation and the quality of the exhaust blower, you should define your own schedule.

As a starting point, we recommend the following schedule:

As necessary

- Clean engraving table
- Clean main enclosure
- Clean top door window

Every 8 hours of engraving

- Clean X-Axis and Y-Axis bearings
- Clean X-Axis and Y-Axis rails and bearing tracks
- Clean X-Axis belt
- Check beam window, #2 mirror, #3 mirror and focus lens for debris. Clean ONLY if dirty.

Every month

- Clean cooling fan filters
- Clean Z-Axis lead screws with white lithium grease
- Check for X-Axis and Y-Axis belt wear. Replace as necessary.
- Check and/or clean X-Axis and Y-Axis drive gears
- Check for X-Axis and Y-Axis bearing wear. Replace as necessary.
- Inspect system for loose screws and mechanical parts. Tighten as necessary.

Every 6 months

- Clean exhaust plenum

Note: If you are noticing a considerable build-up of debris on the optics and the motion system, clean the system at more frequent intervals. If your system has remained relatively clean, you can extend your cleaning intervals. Keep in mind that a clean laser system is a better performing laser system and can extend the life of the parts as well as reduce down time. If you have any questions about maintaining the laser system, please contact our Customer Service Team.