

SECTION 7

Maintenance

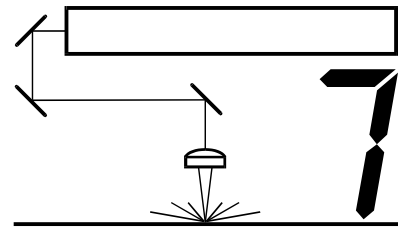

Keeping the laser system clean will ensure the highest quality engraving. The frequency of cleaning will depend entirely on the type of material being engraved, the performance of your exhaust blower, the operating environment, and the amount of laser system usage over a given period of time. Dirt or debris that is allowed to build up on the motion system components will cause uneven or rough engraving, or loss of engraving position as well as premature component failure. Smoke or dirt buildup on the optics can cause damage to them, loss of laser power, or premature failure of these components. Use good judgment and keep in mind that a clean machine is the best performing machine.



Always turn the laser engraving system OFF and unplug it before performing any cleaning procedures.

Suggested Cleaning and Maintenance Supplies

- Soap solution mixture of 1 tablespoon (2 cl) liquid soap and 1 quart (liter) of water in a spray bottle
- Paper towels
- Cotton cloth
- Denatured alcohol (**NOT** to be used on any painted surface, plastic, or the Top Window)
- Acetone (can be used on the engraving table but nowhere else)

- Cotton swabs (supplied)
- Lens cleaner (supplied)
- Lens tissue (supplied)

- Vacuum cleaner
- Set of Allen wrenches sized from .050 to 3/16 inch

***NOTE:** When using acetone or denatured alcohol, please follow the instructions on the printed label of these materials for safe handling procedures.

Please familiarize yourself with the motion system components in the following diagram. It will help you understand which components need periodic cleaning.

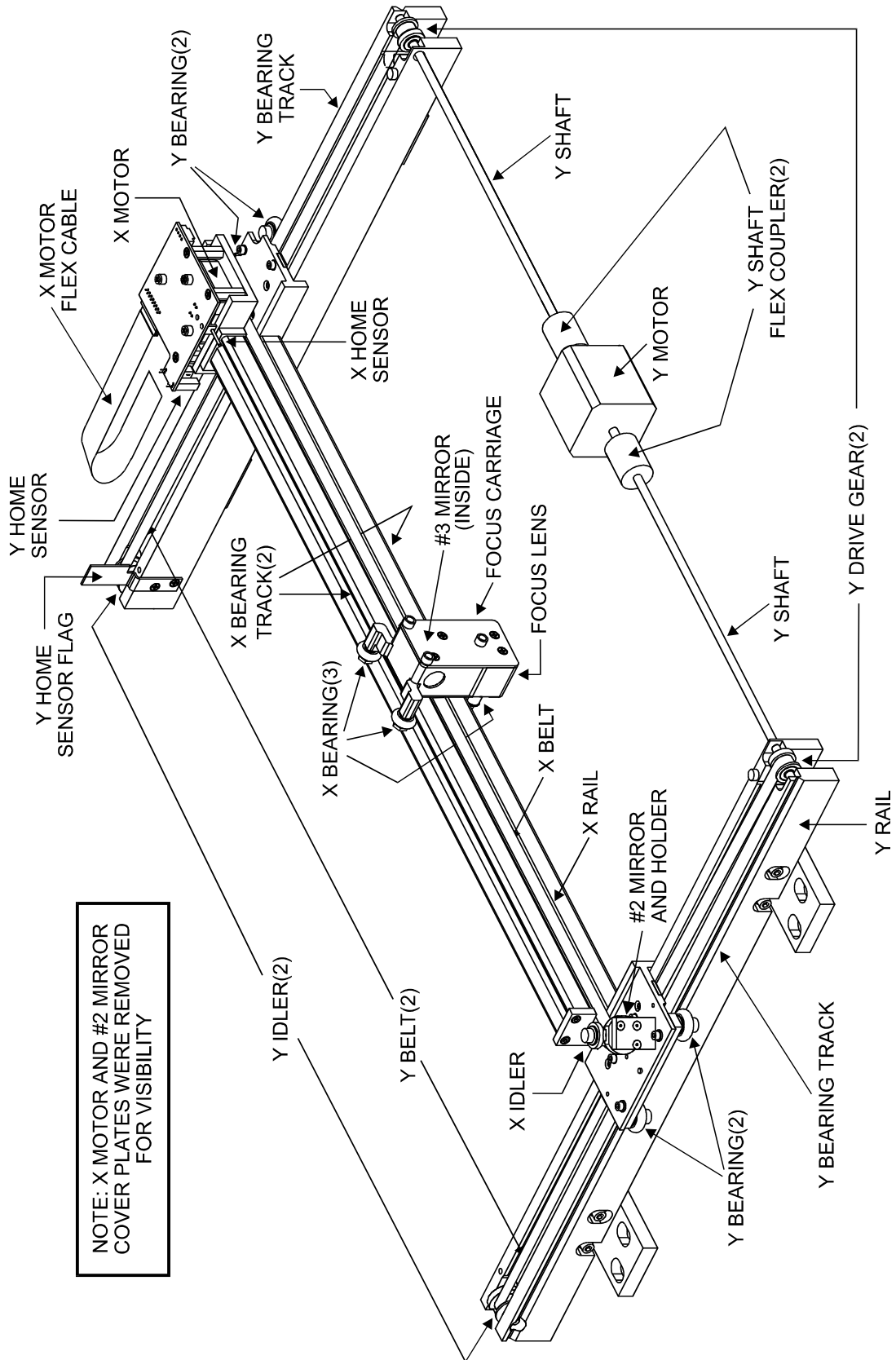

System Cleaning

- Turn off and unplug the laser system.
- Open the Top Door and thoroughly remove all loose dirt and debris from inside the machine with a vacuum cleaner.
- Clean the Engraving Table surface with either a soap solution, alcohol, or acetone, and paper towels. **NEVER** pour or spray any solution directly into the laser system. Always dampen your paper towel or cloth outside of the machine with the cleaning solution and then wipe down the parts you are cleaning with the dampened cloth.
- Clean X Rail and the Y Rails by using either the cotton swabs or paper towels, and alcohol or soap solution. Pay close attention to the bearing tracks that the bearings roll in since any debris left to build up in these bearing tracks will cause the bearings to wear and the engraving quality to become rough.
- After the rails and tracks are cleaned, use a clean swab or paper towel, and alcohol to clean all of the bearings by holding the swab against each bearing and moving the motion system by hand to roll the bearings against the swab. There are seven bearings in the system, three (3) on the Focus Carriage, two (2) on the left side of the X Rail, and two (2) on the right side of the X Rail.
- Clean the Top Window with a cotton cloth and the soap solution. The Top Window is made out of acrylic. **DO NOT** use paper towels because they will scratch the acrylic. Also, **DO NOT** use window cleaner, alcohol, or acetone, as these chemicals will crack the acrylic. Only use cleaners designed for acrylic.
- Use a soft cloth or paper towels and the soap solution to clean the enclosure. **DO NOT** use alcohol, acetone, or any other harsh chemical as this will damage the paint.

Optics Cleaning

A visual inspection of the #2 and #3 Mirrors, Beam Window, and Focus Lens should be performed at least once a day.

CAUTION

DO NOT clean an optic that is visually clean. Excessive cleaning can damage the optics. The #3 Mirror and the Focus Lens will need to be removed to clean them, the #2 Mirror and the Beam Window does not.

Before cleaning the optics, we recommend that you wash your hands thoroughly to prevent contamination. **NEVER** touch any optic with your fingers. The acids from your skin can destroy the coatings on the optics.

#2 Mirror

To gain access to the #2 Mirror, the mirror cover must be removed. Remove the thumbscrew, slide the cover to the right slightly and lift straight up.

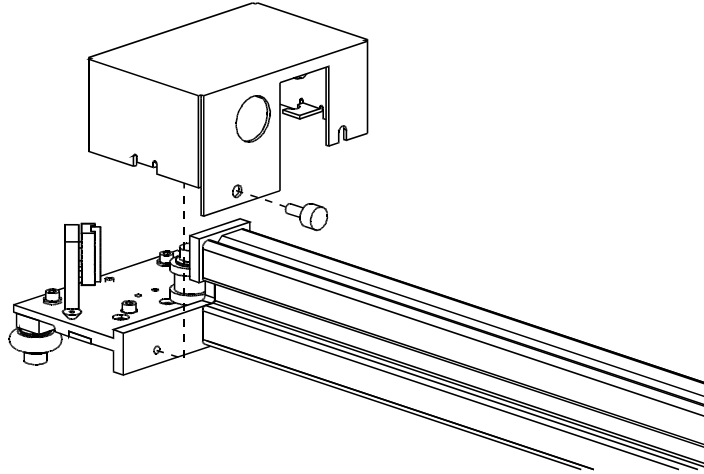

Inspect the #2 Mirror and clean it only if there is debris present. There are two ways to clean the mirror, with a moistened cotton swab or a moistened lens tissue.

MOISTENED COTTON SWAB

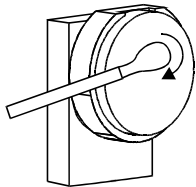

OR

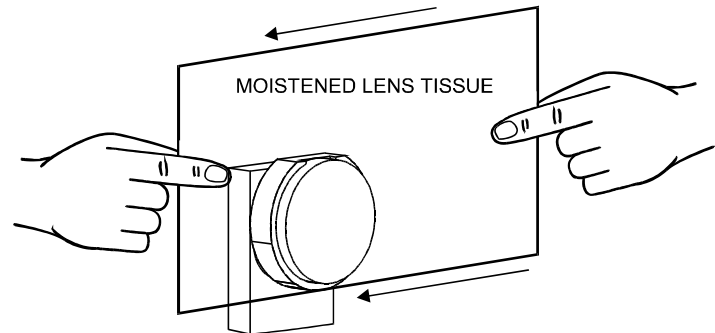

To clean the #2 Mirror with a cotton swab, moisten the cotton swab with the Lens Cleaning solution supplied with the laser system. **DO NOT** use other types of cleaners or solutions. Gently roll the cotton swab across the mirror once. **DO NOT** drag the swab or roll it back and forth as this can scratch the mirror. If the mirror did not come clean, use a fresh cotton swab and repeat the procedure. Do not worry about small pieces of lint that come off of the cotton swab. They will be vaporized as soon as the laser hits it. You can cause more damage to the mirror by trying to get it off than by leaving it alone.

The other method is to use a piece of lens tissue and the Lens Cleaning solution. Place a drop of solution onto the lens tissue. Grasp the tissue by the edges and drag the moistened tissue across the #2 mirror in one direction. If the #2 mirror does not come clean in the first attempt, repeat the procedure with a fresh piece of moistened lens tissue. **DO NOT** re-use the same lens tissue twice and **DO NOT** put any finger pressure on the surface of the mirror as this can scratch it.

#3 Mirror and Focus Lens

You must remove the front cover to the Focus Carriage to gain access to the #3 Mirror and the Focus Lens. To do this, hold the front cover with one hand and with the other hand, remove the three(3) thumbscrews that attach the front cover to the Focus Carriage, and pull the front cover straight out. You will notice that the #3 Mirror and the Focus lens are both mounted to the front cover. Refer to the diagram below.

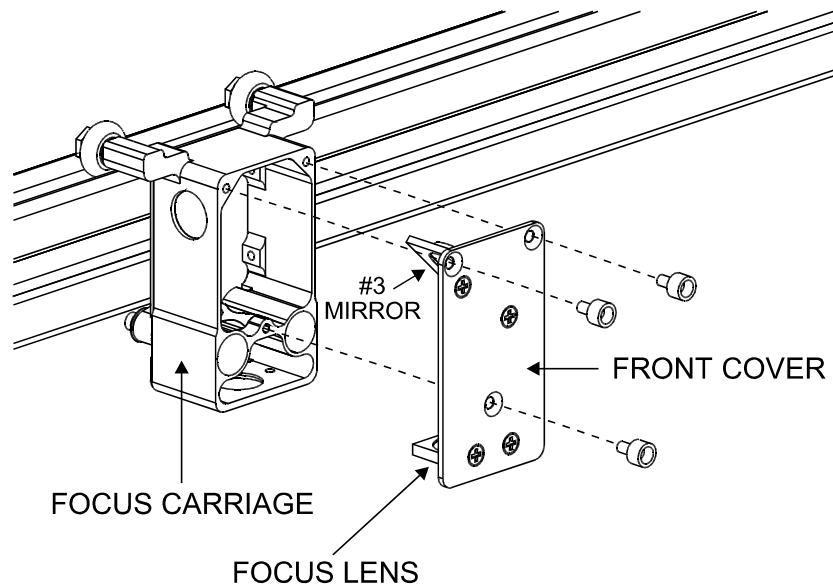

The #3 Mirror and the Focus lens are both glued to a metal bracket and the metal bracket is attached to the front plate with Phillips head screws. It is not necessary to detach the bracket from either optic in order to clean them. Simply tilt the front cover at enough angle so that you can apply the Lens Cleaning solution directly to the #3 Mirror and to the Focus Lens. Flood the surfaces with the solution. If heavy debris is present, let the solution soak in for a minute. Roll a fresh cotton swab across the #3 Mirror to dry it off. Remember that it is okay if a small amount of lint from the cotton swab remains on the mirror. Repeat this procedure for the Focus lens and always use a fresh swab.

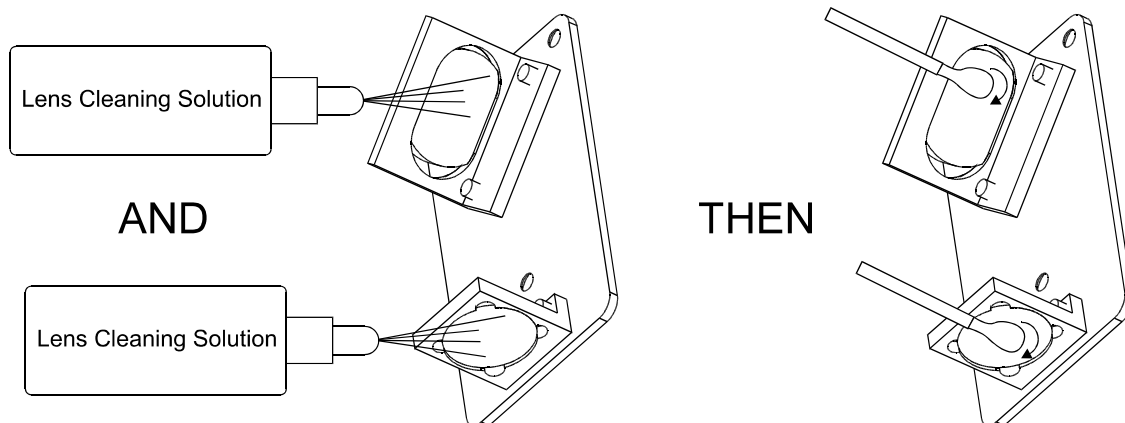

Beam Window

The Beam Window is where the laser beam enters into the engraving area. It is located in the upper left hand corner of the engraving area against the back wall and is yellow in color. It is not necessary to remove the Beam Window for cleaning since it can only get dirty on the front side. The backside is in a sealed environment. To clean the Beam Window, moisten a cotton swab and gently roll it across. Basically, clean it in the same manner as the #2 Mirror.

AUTOFOCUS Sensor and Reflector (if installed)

Engraving smoke can adhere to both the sensor and the reflector of the AUTOFOCUS system. If this happens, you will notice that when you turn AUTOFOCUS on and press the “Z” button, the engraving table will go all the way down to the bottom and get stuck. You will then need to call our service department so that we can assist you into getting the system back to normal operation. To prevent this problem from occurring, you should clean the sensor and reflector periodically. How often you clean them is dependent on the types of materials you are engraving and the quality of your exhaust system. The diagram below shows the locations of these parts.

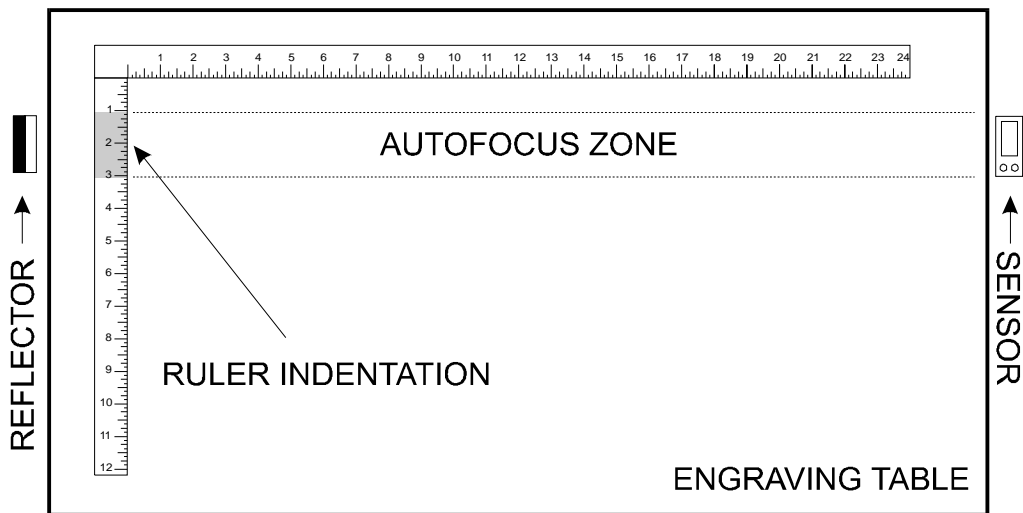

To clean these parts, dampen a soft cotton cloth with water and gently wipe across the reflective surface in one direction. **DO NOT** rub hard or create scratches in the plastic, otherwise the AUTOFOCUS system will malfunction. **DO NOT** use any type of cleaners, only use water or a light solution of hand soap and water on the sensor or reflector.

You can observe if the sensor is working properly by lowering the table so that you have clear sight of the sensor and the reflector. Look at the sensor and notice that the green LED will illuminate. Pass your hand in front of the sensor and watch the red LED turn on as your hand passes through the path, and the red LED will turn OFF when your hand clears the path. Contact our service department if you have any other concerns about the operation or maintenance of the AUTOFOCUS system.

Adjustments and Lubrication

There are no periodic adjustments required. The bearings in the motion system will self adjust to take up any clearances as they begin to wear. The belts are fiber reinforced and will not stretch under normal use so that periodic tension adjustment is not necessary. Optical alignment is not necessary because the laser and the #2 Mirror are fixed.

All bearings in the system are sealed and do not require lubrication. **DO NOT** lubricate the tracks that the bearings ride in. The only lubrication that may be required is the screw threads for the table lifting mechanism. After some time, contaminants can adhere to the lubricant, which can cause the engraving table to bind up or sound squeaky. If this is the case, wipe off the contaminated grease with a soft cloth and apply fresh white lithium grease to the screw threads. Run the table up and down to work in the fresh grease.

Electronic Upgrading

The laser systems onboard computer is equipped with a special “Flash” upgrade technology. If the electronic operation of the system should ever require upgrading, it can be done electronically without the changing of any parts. The upgrade file gets downloaded from your computer to the laser system via the parallel port. This file is then run on the laser system and it only takes a few minutes. Once the file has completely run, the laser system will automatically restart and the new changes will take effect. For more specific details, please refer to the instructions that will accompany the flash disk.

Fuse Replacement

If a fuse must be replaced, use only the following type:

USA

5 x 20 mm, Glass, time delay, 250V, 10A fuse, UL approved

Europe and other countries

5 x 20 mm, Glass, time delay, 250V, 5A fuse, designed to IEC 127-2 sheet 3, and approved by a recognized European testing agency.

Battery Replacement



There is a danger of explosion if the battery is incorrectly replaced. Replace the battery only with the same or equivalent type recommended by the battery manufacturer. Using an incorrect battery, recharging or disassembling the battery may present a danger due to fire or explosion. Dispose of used batteries promptly according to the local regulations.

Cooling Fan Filters

This air-cooled laser system will require periodic cleaning of the cooling fan filters. Since ambient air is used to cool the laser tube, the air must be filtered before it enters the inside of the laser system otherwise dirt and dust can build up inside of the laser system and damage it. The contaminants reduce the laser system's cooling ability and will cause the laser tube to overheat.

An overheated tube will lose laser power during engraving and will eventually shut down completely. The laser tube has a built in safety mechanism that will shut the beam off before it can damage itself.

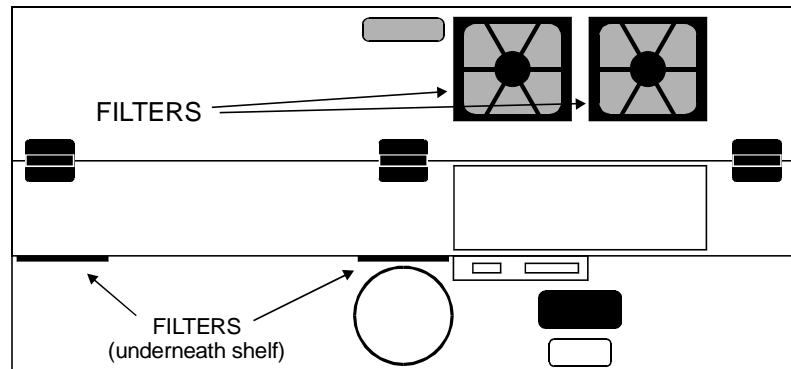

The cooling fan filters are located on the back of the laser system. Do not push the laser system all the way back against the wall because air needs to circulate behind the laser system. Since there is a variety of laser power options available for this class of laser system, **the cooling fan filters may differ in appearance compared to your system.** Regardless, you should remove and clean these filters at least once a week depending on your environmental conditions. Dirtier environments require more frequent cleanings. To remove the filter(s), simply snap off the black cover and remove the foam element. Wash the element in a soap and water solution, dry, and re-install.



NEVER OPERATE THE LASER SYSTEM WITH THE COOLING FAN FILTERS REMOVED. This can permanently damage the laser system. Damage from this kind of abuse WILL NOT be covered under warranty.

Maintenance Schedule

Since the maintenance requirements of the laser system is dependent on the type of material being run, the quantity of material being removed, the hours of operation, and the quality of the exhaust blower, it must be user defined. As a starting point, we recommend checking and, if necessary, cleaning the laser system after every 8 hours of engraving or cutting. Depending on your particular operation, you may need to adjust this schedule. If you are noticing a considerable buildup of debris on the optics and the motion system, clean the system at more frequent intervals. If your system has remained relatively clean, you can extend your cleaning intervals. You need to be the judge but keep in mind that a clean machine is a better performing machine and can extend the life of the parts as well as reduce the possibility of down time. Maintaining and cleaning the laser system should not take more than five (5) minutes a day. If you have any questions about maintaining the laser system, please contact our Service Department.